

## ■ Description

FA3629AV is a Power IC which includes DC-DC converter controller and Nch-power MOSFET. This IC can directly drive Nch/Pch MOSFET. This IC is suitable to reduce converter size because it has many functions in a small package TSSOP.

## ■ Features

- Low input voltage: 2.5V to 6.5V
- 40V CDMOS Process:
  - Built-in 0.3Ω Nch-Power MOSFET(ch1, open drain)
- 3-channels PWM Control:
  - 2 boost circuits(ch1, ch2), 1 inverting circuit (ch3)
- Adjustable soft start time and maximum duty cycle
- Built-in timer latch for short circuit protection:
  - Delay time =  $2^{16}$  / (switching frequency)
- Built-in protection functions: Overcurrent limit for MOSFET, overheat protection, undervoltage lockout
- Wide range of operation frequency: 100kHz to 1MHz
- Package: TSSOP-16(Thin and small)

## ■ Applications

- Power supply for general equipment

## ■ Dimensions, mm

### ● TSSOP-16

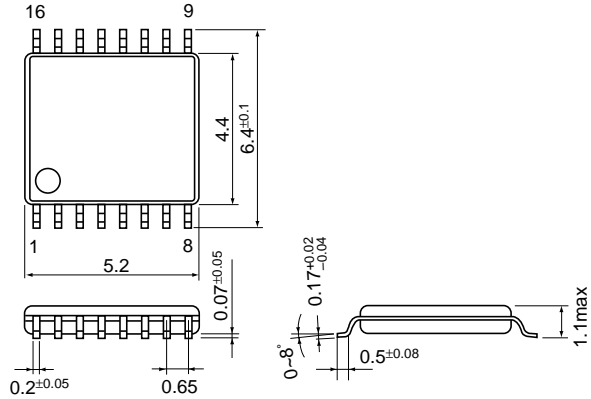

## ■ Block diagram

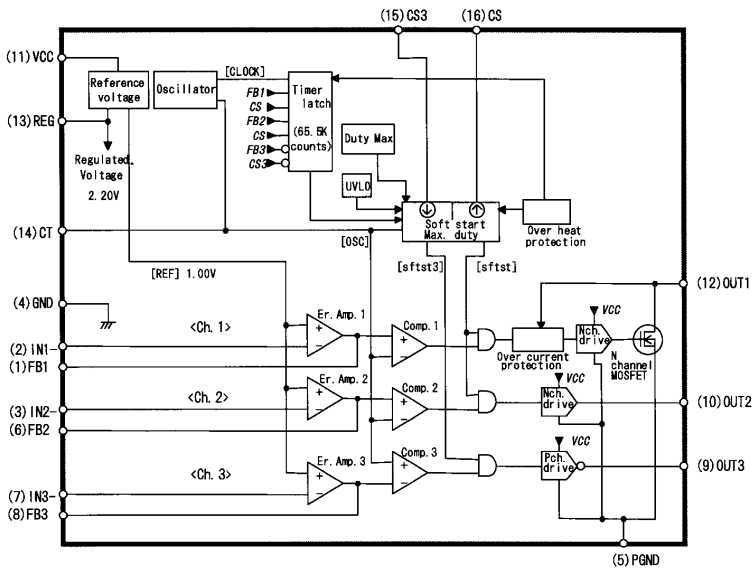

Pin No.	Pin symbol	Description
1	FB1	Ch.1 output of error amplifier
2	IN1-	Ch.1 inverting input to error amplifier
3	IN2-	Ch. 2 inverting input to error amplifier
4	GND	Ground of control blocks
5	PGND	Ground of large power blocks
6	FB2	Ch. 2 output of error amplifier
7	IN3-	Ch. 3 inverting input to error amplifier
8	FB3	Ch. 3 output of error amplifier
9	OUT3	Ch. 3 output (for Pch-MOSFET)
10	OUT2	Ch. 2 output (for Nch-MOSFET)
11	VCC	Power supply
12	OUT1	Ch.1 drain output of internal Nch-MOSFET
13	REG	Regulated voltage output
14	CT	Oscillator timing capacitor
15	CS3	Soft start for Ch. 3
16	CS	Soft start for Ch.1 and Ch. 2

### ■ Absolute maximum ratings

Item	Symbol	Rating	Unit
Power supply voltage	V <sub>CC</sub>	6.5	V
Output voltage at OUT1 pin	V <sub>OUT1</sub>	40	V
Output current at OUT1 pin*1	I <sub>OUT1</sub>	2.8	A
Source peak current of OUT2	I <sub>OUT2+</sub>	-400	mA
Sink peak current of OUT2	I <sub>OUT2-</sub>	400	mA
Source peak current of OUT3	I <sub>OUT3+</sub>	-400	mA
Sink peak current of OUT3	I <sub>OUT3-</sub>	400	mA
Source average current of OUT2	I <sub>OUT2+</sub>	-50	mA
Sink average current of OUT2	I <sub>OUT2-</sub>	50	mA
Source average current of OUT3	I <sub>OUT3+</sub>	-50	mA
Sink average current of OUT3	I <sub>OUT3-</sub>	50	mA
Input voltage to err. amp.	V <sub>EI</sub>	5.0	V
Total power dissipation*2	P <sub>d</sub>	500	mW
Ambient temperature	T <sub>OPR</sub>	-25 to +95	°C
Junction temperature	T <sub>J</sub>	125	°C
Storage temperature	T <sub>STG</sub>	-40 to +125	°C

\*1 Output current is limited by the overcurrent protection

\*2 Ta < 25°C

### ■ Recommended operating conditions

Item	Symbol	Min.	Max.	Unit
Power supply voltage	V <sub>CC</sub>	2.5	5.8	V
Output voltage of OUT1	V <sub>OUT1</sub>	0	32	V
Output current of OUT1	I <sub>OUT1</sub>	0	1.8	A
Oscillation frequency	f <sub>OSC</sub>	100	1000	kHz
Ambient temperature	T <sub>OPR</sub>	-20	85	°C

### ■ Electrical characteristics (V<sub>CC</sub>=3.0V, Ta=25°C)

#### Reference voltage section

Item	Symbol	Test condition	Min.	Typ.	Max.	Unit
Reference voltage	V <sub>REF</sub>		0.98	1.00	1.02	V
Variation with supply voltage	V <sub>REF-LINE</sub>	V <sub>CC</sub> =2.5 to 5.8V		1	3	mV
Variation with temperature	V <sub>REF-TC1</sub>	Ta=-20 to +25°C		0.5	1.2	%
	V <sub>REF-TC2</sub>	Ta=+25 to +85°C		0.5	1.2	%

#### Regulated voltage for internal control blocks

Item	Symbol	Test condition	Min.	Typ.	Max.	Unit
Regulated voltage	V <sub>REG</sub>	C <sub>O</sub> =0.1μF	2.16	2.20	2.24	V
Variation with supply voltage	V <sub>REG-LINE</sub>	V <sub>CC</sub> =2.5 to 5.8V		3	8	mV
Variation with temperature	V <sub>REG-TC1</sub>	Ta=-20 to +25°C		0.5	1.5	%
	V <sub>REG-TC2</sub>	Ta=+25 to +85°C		0.7	1.5	%
Source current	I <sub>REG</sub>		-40		-15	mA

#### Oscillator section

Item	Symbol	Test condition	Min.	Typ.	Max.	Unit
Oscillation frequency	f <sub>OSC</sub>	C <sub>T</sub> =150pF	480	550	620	kHz
High level voltage	V <sub>OSCH</sub>	C <sub>T</sub> =150pF		1.38		V
Low level voltage	V <sub>OSCL</sub>	C <sub>T</sub> =150pF		0.78		V
Variation with supply voltage	f <sub>dv</sub>	V <sub>CC</sub> =2.5 to 5.8V		1	2	%
Variation with temperature	f <sub>dT1</sub>	Ta=-20 to +25°C		5	7	%
	f <sub>dT2</sub>	Ta=+25 to +85°C		5	7	%

**Soft-start and duty section**

Item	Symbol	Test condition	Min.	Typ.	Max.	Unit
Charge current of CS (Source)	I <sub>CS</sub>		-1.2	-1.0	-0.8	μA
Charge current of CS3 (Sink)	I <sub>CS3</sub>		0.8	1.0	1.2	μA
Max. duty cycle of OUT1 & OUT2	D <sub>max</sub>	f <sub>osc</sub> =500kHz	80	87	90	%
Max. duty cycle of OUT3	D <sub>max3</sub>	f <sub>osc</sub> =500kHz	80	86	90	%
Invalid TL threshold voltage of CS	V <sub>CSLO</sub>		0.42	0.52	0.62	V
Invalid TL threshold voltage of CS3	V <sub>CSHI</sub>		1.58	1.68	1.78	V

**Timer latch section (TL)**

Item	Symbol	Test condition	Min.	Typ.	Max.	Unit
Threshold voltage of FB1 (Ch.1)	V <sub>TLTH1</sub>		1.58	1.68	1.78	V
Threshold voltage of FB2 (Ch. 2)	V <sub>TLTH2</sub>		1.58	1.68	1.78	V
Threshold voltage of FB3 (Ch. 3)	V <sub>TLTH3</sub>		0.42	0.52	0.62	V
Start up count	count		-	2 <sup>16</sup>	-	counts
Start up time	T <sub>TL</sub>	C <sub>T</sub> =150pF	105	119	137	ms

**Error amplifier section**

Item	Symbol	Test condition	Min.	Typ.	Max.	Unit
Input offset voltage	V <sub>IO</sub>				10	mV
Common mode input voltage range	V <sub>COM</sub>		0.2		1.5	V
DC open loop gain	A <sub>VO</sub>		70	75	80	dB
Unity gain band width	f <sub>T</sub>		1.0	1.7	2.0	MHz
Sink current (Ch.1)	I <sub>OL1</sub>	V <sub>FB1</sub> =0.5V	1.0	1.5	2.0	mA
Source current (Ch.1)	I <sub>OH1</sub>	V <sub>FB1</sub> =V <sub>REG</sub> -0.5V	-160	-120	-80	μA
Sink current (Ch. 2)	I <sub>OL2</sub>	V <sub>FB2</sub> =0.5V	0.5	0.7	0.9	mA
Source current (Ch. 2)	I <sub>OH2</sub>	V <sub>FB2</sub> =V <sub>REG</sub> -0.5V	-160	-120	-80	μA
Sink current (Ch. 3)	I <sub>OL3</sub>	V <sub>FB3</sub> =0.5V	1.0	1.5	2.0	mA
Source current (Ch. 3)	I <sub>OH3</sub>	V <sub>FB3</sub> =V <sub>REG</sub> -0.5V	-160	-120	-80	μA
Sink current variation with temperature	I <sub>OL-TC1</sub>	T <sub>a</sub> =-20 to +25°C			20	%
	I <sub>OL-TC2</sub>	T <sub>a</sub> =+25 to +85°C			20	%
Source current variation with temperature	I <sub>OH-TC1</sub>	T <sub>a</sub> =-20 to +25°C			20	%
	I <sub>OH-TC2</sub>	T <sub>a</sub> =+25 to +85°C			20	%

**Overcurrent protection section (OCP)**

Item	Symbol	Test condition	Min.	Typ.	Max.	Unit
Threshold current	I <sub>OC DTH</sub>	V <sub>CC</sub> =3.0V	1.4	1.8	2.0	A
		V <sub>CC</sub> =5.0V	1.8	2.0	2.2	A
Delay time	t <sub>OC D</sub>		100	200	400	ns

**Overheat protection section (OHP)**

Item	Symbol	Test condition	Min.	Typ.	Max.	Unit
Threshold temperature	T <sub>OH</sub>		125	135	145	°C

**Undervoltage lockout circuit section (UVLO)**

Item	Symbol	Test condition	Min.	Typ.	Max.	Unit
Threshold voltage of REG	V <sub>UVTH</sub>		1.95	2.05	2.15	V

**Output section (OUT1)**

Item	Symbol	Test condition	Min.	Typ.	Max.	Unit
On resistance of MOSFET	R <sub>ON1</sub>	V <sub>CC</sub> =3.0V, I <sub>O1</sub> =200mA	0.25	0.275	0.3	Ω
Rise time of OUT1	t <sub>r</sub>	V <sub>CC</sub> =3.0V		25	35	ns
Fall time of OUT1	t <sub>f</sub>	V <sub>OUT1</sub> =10V, I <sub>O1</sub> =1.0A		25	35	ns

**Output section (OUT2, OUT3)**

Item	Symbol	Test condition	Min.	Typ.	Max.	Unit
Rise time of OUT2	t <sub>r2</sub>	V <sub>CC</sub> =3V, C <sub>O2</sub> =1000pF	20	25	35	ns
Fall time of OUT2	t <sub>f2</sub>	(Between OUT2-GND)	20	25	35	ns
Rise time of OUT3	t <sub>r3</sub>	V <sub>CC</sub> =3V, C <sub>O3</sub> =1000pF	20	25	35	ns
Fall time of OUT3	t <sub>f3</sub>	(Between VCC-OUT3)	20	25	35	ns
High level on resistance of OUT2	R <sub>2AH</sub>	V <sub>CC</sub> =3V, I <sub>OUT2</sub> =-150mA	2.5	4.0	5.5	Ω
Low level on resistance of OUT2	R <sub>2AL</sub>	V <sub>CC</sub> =3V, I <sub>OUT2</sub> =150mA	2.5	4.0	5.5	Ω
High level on resistance of OUT3	R <sub>3AH</sub>	V <sub>CC</sub> =3V, I <sub>OUT3</sub> =-150mA	2.5	4.0	5.5	Ω
Low level on resistance of OUT3	R <sub>3AL</sub>	V <sub>CC</sub> =3V, I <sub>OUT3</sub> =150mA	2.5	4.0	5.5	Ω
High level on resistance of OUT2	R <sub>2AH</sub>	V <sub>CC</sub> =5V, I <sub>OUT2</sub> =-150mA	2.0	3.5	5.0	Ω
Low level on resistance of OUT2	R <sub>2AL</sub>	V <sub>CC</sub> =5V, I <sub>OUT2</sub> =150mA	2.0	3.5	5.0	Ω
High level on resistance of OUT3	R <sub>3AH</sub>	V <sub>CC</sub> =5V, I <sub>OUT3</sub> =-150mA	2.0	3.5	5.0	Ω
Low level on resistance of OUT3	R <sub>3AL</sub>	V <sub>CC</sub> =5V, I <sub>OUT3</sub> =150mA	2.0	3.5	5.0	Ω

**Overall device**

Item	Symbol	Test condition	Min.	Typ.	Max.	Unit
Operating current (Overall)	I <sub>CCA</sub>	D=50%, f <sub>osc</sub> =500kHz		3.0	3.8	mA
Operating current of control blocks	I <sub>CTRL</sub>			1.8		mA

■ Characteristic curves (Ta=25°C)

Supply current (I<sub>cc</sub>) vs oscillation frequency (f<sub>osc</sub>)

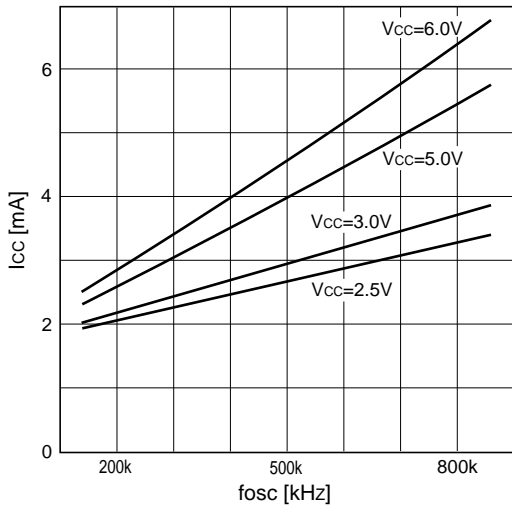

Oscillation frequency (f<sub>osc</sub>) vs. timing capacitor (C<sub>T</sub>)

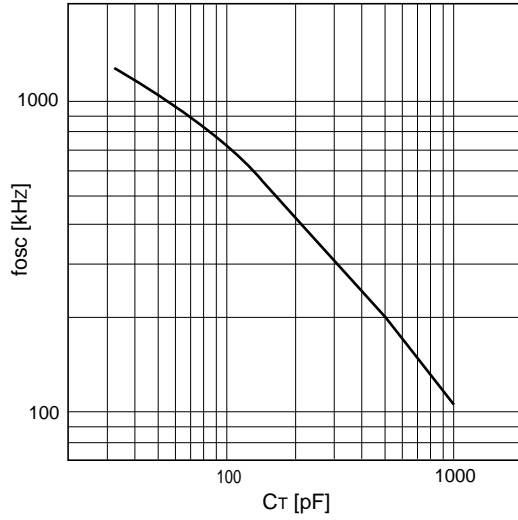

Oscillation frequency (f<sub>osc</sub>) vs. ambient temperature (Ta)

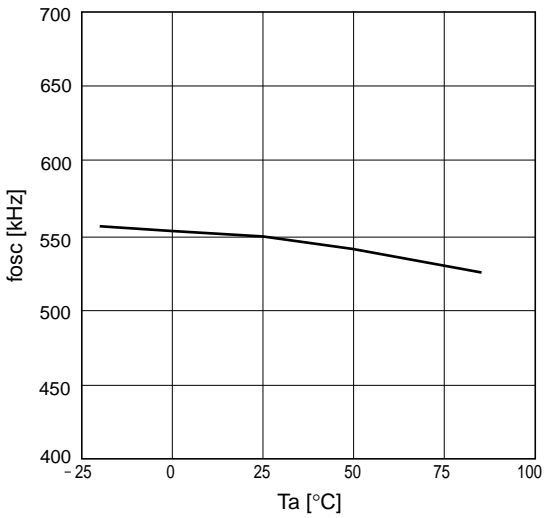

Max. on duty cycle vs. oscillation frequency (f<sub>osc</sub>)

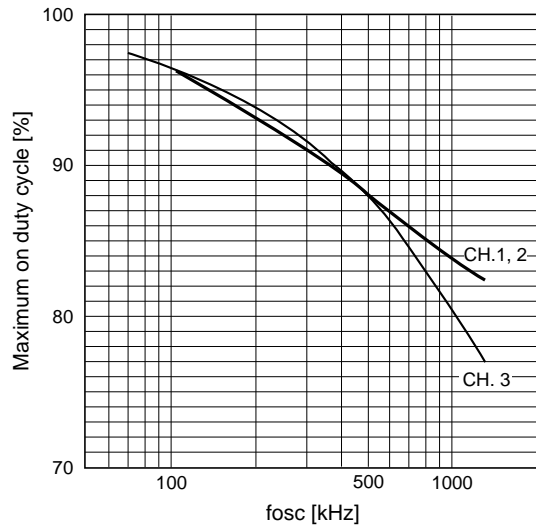

Oscillation peak voltage vs. timing capacitor (C<sub>T</sub>)

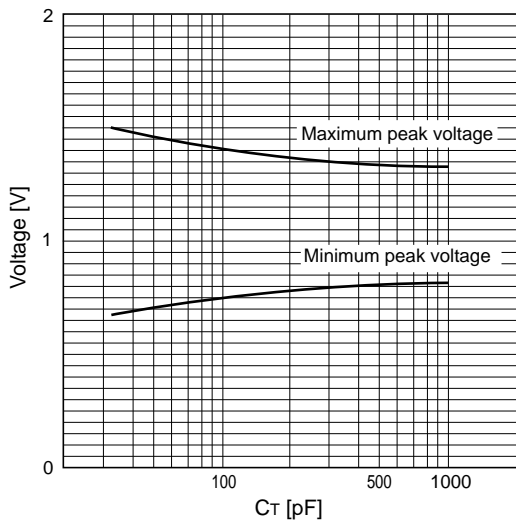

Error amplifier voltage gain (A<sub>v</sub>) /phase vs. frequency (f)

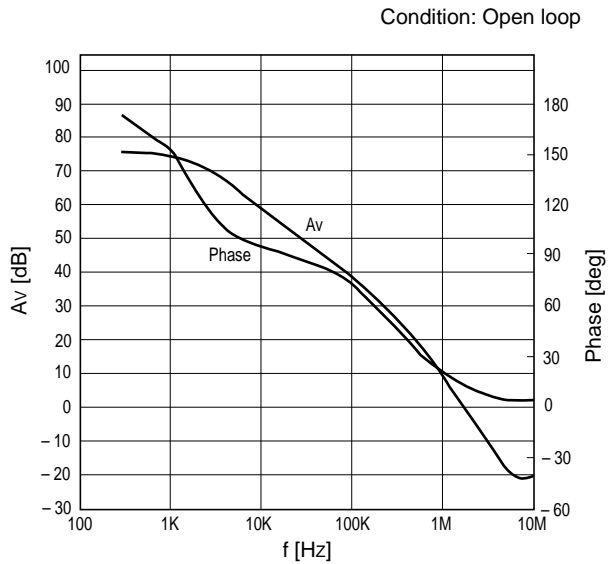

Output (Ch. 2) duty cycle vs FB terminal voltage (VFB)

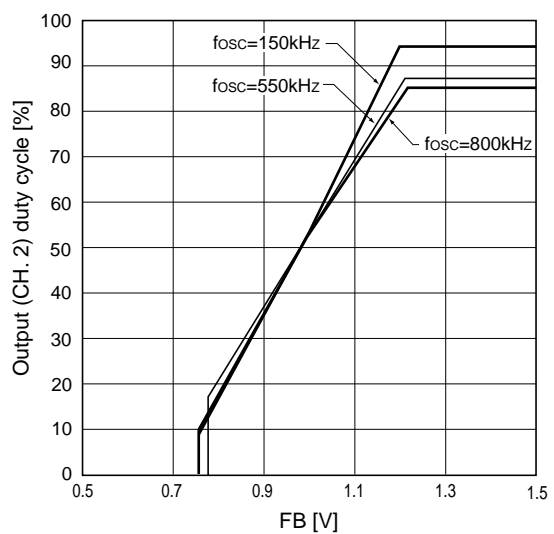

Output (Ch. 3) duty cycle vs. FB3 terminal voltage (VFB3)

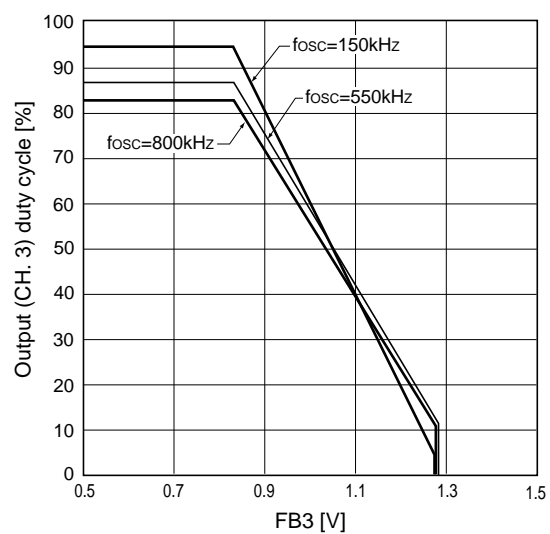

H-level output voltage (VoH) vs output source current (Iso)

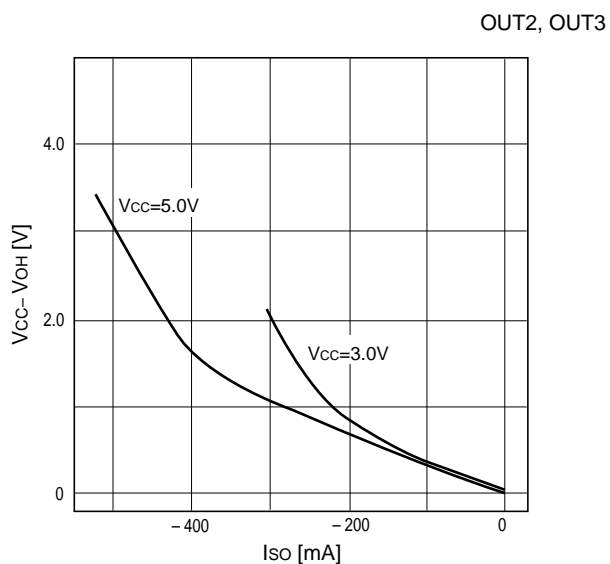

L-level output voltage (VoL) vs. output sink current (Isi)

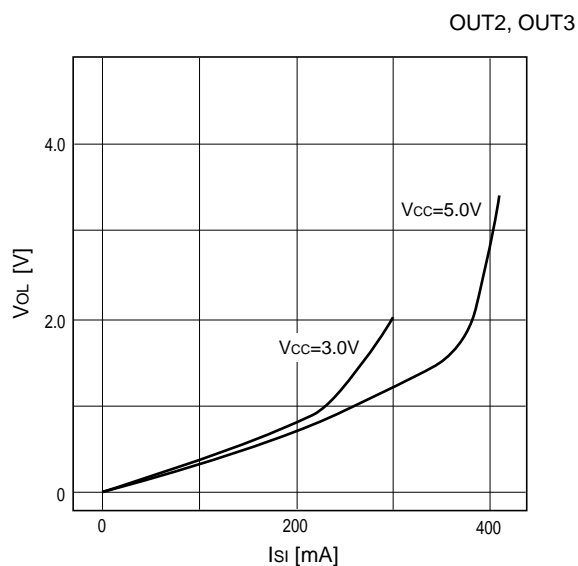

■ Application circuit

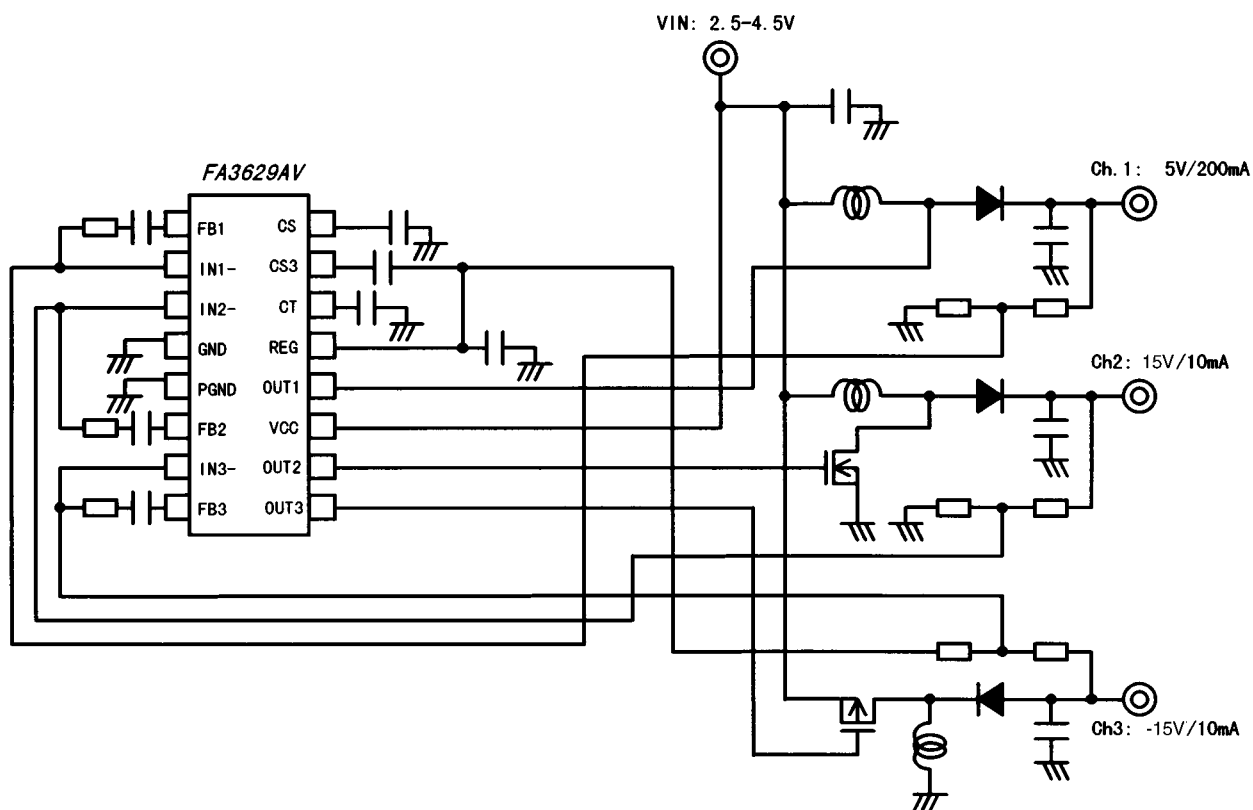

*Parts tolerances characteristics are not defined in the circuit design sample shown above. When designing an actual circuit for a product, you must determine parts tolerances and characteristics for safe and economical operation.*

## WARNING

1. This Data Book contains the product specifications, characteristics, data, materials, and structures as of September 1999. The contents are subject to change without notice for specification changes or other reasons. When using a product listed in this Data Book, be sure to obtain the latest specifications.
2. All applications described in this Data Book exemplify the use of Fuji's products for your reference only. No right or license, either express or implied, under any patent, copyright, trade secret or other intellectual property right owned by Fuji Electric Co., Ltd. is (or shall be deemed) granted. Fuji makes no representation or warranty, whether express or implied, relating to the infringement or alleged infringement of other's intellectual property rights which may arise from the use of the applications described herein.
3. Although Fuji Electric is enhancing product quality and reliability, a small percentage of semiconductor products may become faulty. When using Fuji Electric semiconductor products in your equipment, you are requested to take adequate safety measures to prevent the equipment from causing a physical injury, fire, or other problem if any of the products become faulty. It is recommended to make your design fail-safe, flame retardant, and free of malfunction.
4. The products introduced in this Data Book are intended for use in the following electronic and electrical equipment which has normal reliability requirements.
  - Computers      • OA equipment      • Communications equipment (terminal devices)      • Measurement equipment
  - Machine tools      • Audiovisual equipment      • Electrical home appliances      • Personal equipment      • Industrial robots etc.
5. If you need to use a product in this Data Book for equipment requiring higher reliability than normal, such as for the equipment listed below, it is imperative to contact Fuji Electric to obtain prior approval. When using these products for such equipment, take adequate measures such as a backup system to prevent the equipment from malfunctioning even if a Fuji's product incorporated in the equipment becomes faulty.
  - Transportation equipment (mounted on cars and ships)      • Trunk communications equipment
  - Traffic-signal control equipment      • Gas leakage detectors with an auto-shut-off feature
  - Emergency equipment for responding to disasters and anti-burglary devices      • Safety devices
6. Do not use products in this Data Book for the equipment requiring strict reliability such as (without limitation)
  - Space equipment      • Aeronautic equipment      • Atomic control equipment
  - Submarine repeater equipment      • Medical equipment
7. Copyright ©1995 by Fuji Electric Co., Ltd. All rights reserved.  
No part of this Data Book may be reproduced in any form or by any means without the express permission of Fuji Electric.
8. If you have any question about any portion in this Data Book, ask Fuji Electric or its sales agents before using the product. Neither Fuji nor its agents shall be liable for any injury caused by any use of the products not in accordance with instructions set forth herein.